

## CONTROL LAYOUT

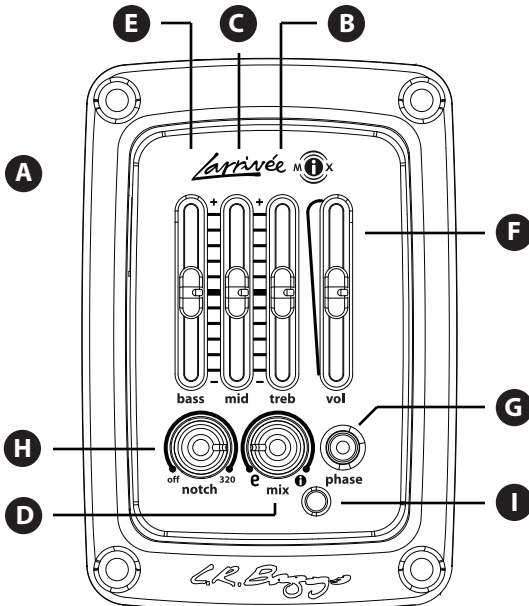

**A. Click-Lock Battery Access:** The 9V battery is located inside of the preamp. To replace it simply push down on the central area of the face plate until you hear a click then slowly release and the preamp will pop up. Next pull the preamp out of the guitar until it locks into place. Holding the preamp by sides, press down on the end of the battery to release it. Observing polarity replace the battery by pushing it up and in until it locks into place. Press down on the preamp until it locks back into place.

**B. Treb:** Adds or subtracts the highest frequencies, "sparkle" or presence sounds.

**C. Mid:** Adds or subtracts the midrange, nasal or "honky" type sounds.

**D. Mix:** Use to blend between Element and iBeam pickups.

**E. Bass:** Adds or subtracts the lower frequencies, tonal warmth or cut to minimize feedback feedback.

**F. Volume:** Yes

**G. Phase Inversion:** This control changes the phase, or polarity, of the signal. The phase of the guitar top, relative to that of the loudspeakers, influences the guitar's stability at high sound levels. The speaker's phase relative to the guitar top is impossible to predict on stage; therefore it is necessary to experiment with this button to find the optimum phase setting for each environment.

**H. Notch Filter:** If, after using the phase inversion, there is still feedback, slowly weep the frequency with the notch filter until it grabs this feedback and eliminates it. This effect will be easy to detect, as the problem frequency will instantly vanish when the knob is in the correct position. With the phase and notch in their optimum positions, you will find that you can play quite a bit louder without feedback.

**I. Battery Status:** The battery status LED remains on at all times when the unit is plugged in. As the battery weakens, the light will gradually dim. You have 10-20 hours left to replace the battery when the light becomes difficult to see. **Caution:** Do not remove or replace the battery while plugged in!